



# KLORIGEN™ K-SERIES

Generate Chlorine Gas and  
Sodium Hypochlorite On-site  
and On-demand

## INHERENTLY SAFER TECHNOLOGY

KLORIGEN™ K-SERIES SYSTEMS SAFELY AND ECONOMICALLY PRODUCE CHLORINE GAS AND MEMBRANE-GRADE SODIUM HYDROXIDE AT THE POINT-OF-USE AND NSF/ANSI STD. 60 COMPLIANT SODIUM HYPOCHLORITE UP TO 15% CONCENTRATION. PRODUCTION CAPACITIES RANGE FROM 500 LBS TO 20 TONS PER DAY.

Eliminate the safety concerns pertaining to the storage and use of pressurized chlorine and the high cost, supply and viability issues associated with bulk chemical suppliers. Klorigen employs technology specifically designed for municipal and industrial water treatment applications.



### FEATURES & BENEFITS

- Direct replacement for pressurized chlorine gas
- Allows continued use of current disinfection methods
- Reduces or eliminates RMP requirements
- Generated product is NSF/ANSI Standard 60 compliant
- Requires minimal maintenance and operator intervention
- Multi-year warranties and maintenance contracts available

### APPLICATIONS

- Potable water treatment
- Wastewater treatment
- Cooling water biocide
- Pulp and paper production
- Mining
- Food processing
- Odor and pH control
- Bleach production
- Power Plants

### ELECTROLYZER

- Partioned cells employ ion-selective Nafion® membranes and coated titanium DSA®
- Vertical cell design eliminates H<sub>2</sub> gas pockets
- Water and brine are purified onboard to ultra pure levels to optimize performance and eliminate cell maintenance (e.g. acid cleaning)

### OPERATING DATA (CONSUMPTION PER LB/CI2)

- Salt: 1.80 lbs
- Water: 0.95 gals
- Electric Power: 1.65 DC / 1.75 AC kWh
- Life cycle maintenance costs as low as \$0.03/lb



**Klorigen™ - Designated "QATT"  
(Qualified Anti-Terrorism Technology)  
by DHS on February 16, 2010 and  
February 6, 2015**

19597 NORTHEAST 10TH AVENUE, NORTH MIAMI BEACH, FLORIDA 33179  
TEL: 305-655-2755 | FAX: 305-655-2669 | EMAIL: INFO@ELECTROLYTICTECH.COM  
WWW.ELECTROLYTICTECH.COM

# Klorigen™ K-Series Specifications

Maximum Daily Production Rates	K-4 Module	K-8 Module	K-16 Module	2 x K-16 Module	4 x K-16 Module	8 x K-16 Module
Chlorine Gas	1,250 ppd	2,500 ppd	5,000 ppd	10,000 ppd	20,000 ppd	40,000 ppd
Sodium Hydroxide @ 15%	965 gpd	1930 gpd	3,860 gpd	7,720 gpd	15,440 gpd	30,880 gpd

or when converted to sodium hypochlorite

Sodium Hypochlorite @ 12.5%	1,250 gpd	2,500 gpd	5,000 gpd	10,000 gpd	20,000 gpd	40,000 gpd
-----------------------------	-----------	-----------	-----------	------------	------------	------------

## Sodium Hypochlorite Application

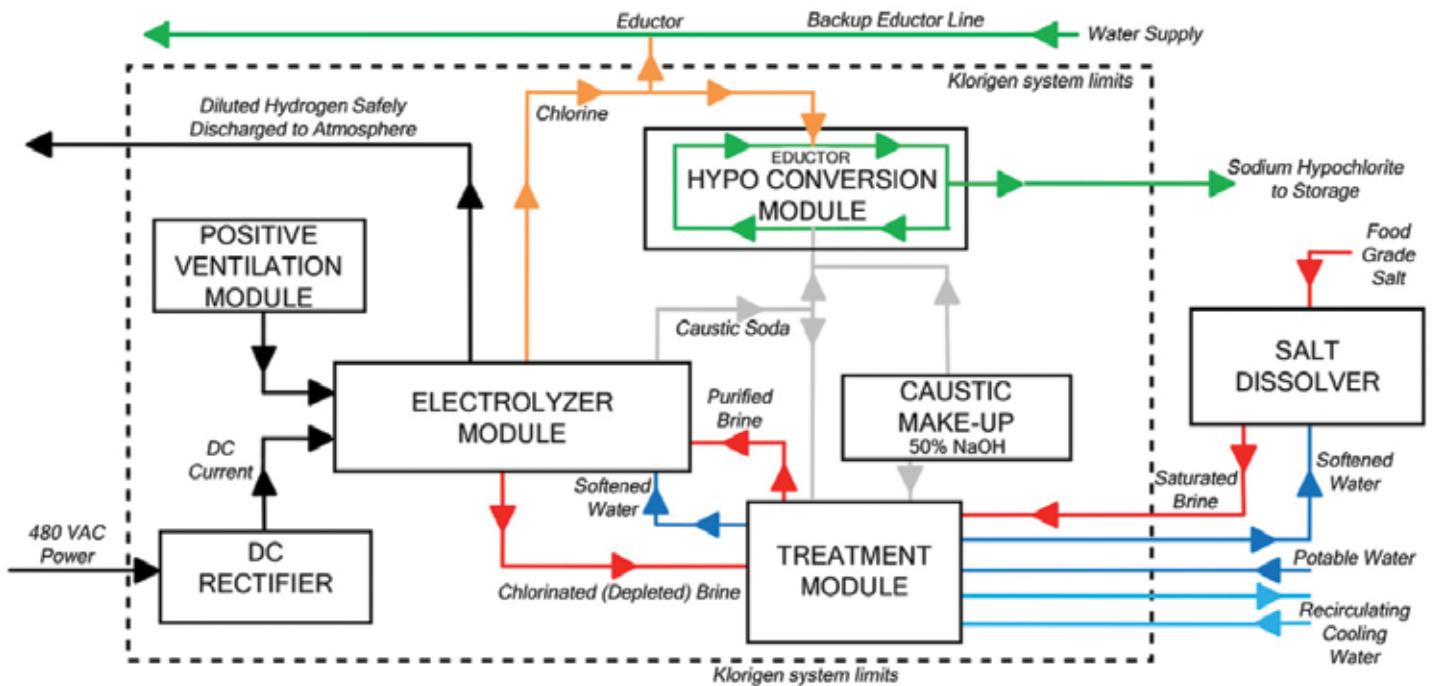

### CONSTRUCTION

- Modular construction reduces installation time and cost
- Structural assemblies of chemical-resistant non-conducting pultruded GRP and UHMWPE
- 316L stainless steel and titanium fasteners
- All piping and valves are thermoplastic welded

### POWER SUPPLY

- Precision engineered SCR regulated DC output
- Constant current regulated to maintain steady state DC output (within +/- 1%)
- Chlorine output directly proportional to power input
- Maximum broadband harmonic suppression
- Oil-cooled units are quiet and clean

### HYDROGEN SAFETY

- Membrane-separated cells isolate electrical potential
- Redundant blowers with airflow safety switches
- Vertical orientation allows natural gas lifting
- Robust electrolyzer construction

### FEATURES & OPTIONS

- PLC capable of interfacing with most SCADA systems for remote control and monitoring
- Brine and products storage tanks and pumps
- Containerized ("monocoque") configurations

